



Bathroom extract fans

DECOR-200 Series

DECOR-200



Range of axial extractors with airflow rates of approx. 180 m³/h, for connection to 120 mm diameter circular ducting. All the fans are manufactured from injection moulded plastic, fitted with neon light indicator and single phase 230V-50Hz, class B motor equipped with overload thermal protection. The "Z" versions incorporate long life motors fitted with ball bearings. All the fans are class II insulation, IP44 rated and suitable to operate with air temperature up to 40°C.

+ Attributes



Back draft shutter
To prevent air entry and limit heat leakage when the extractor is not operating. It opens due to the pressure of the air.

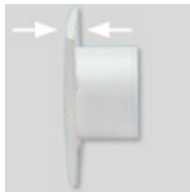

Slimline front grille



Fans suitable to install in bathrooms between 8 and 15 m².

+ Features

	C	CZ	CR	CRZ	CH	CHZ
NEON LIGHT INDICATOR	•	•	•	•	•	•
AUTOMATIC BACK DRAFT SHUTTER	•	•	•	•	•	•
ADJUSTABLE RUN-ON-TIMER			•	•	•	•
ADJUSTABLE HUMIDISTAT					•	•
BALL BEARINGS		•		•		•

+ Technical characteristics

Model	Speed (r.p.m.)	Maximum absorbed power (W)	Voltage (V) 50 Hz	Sound pressure level at 1,5 m (dB(A))	Maximum airflow (m ³ /h)	IP	Ø duct (mm)	Weight (Kg)
DECOR-200	2500	20	230	45,5	185	Class II / IP44	120	0,8

+ Dimensions

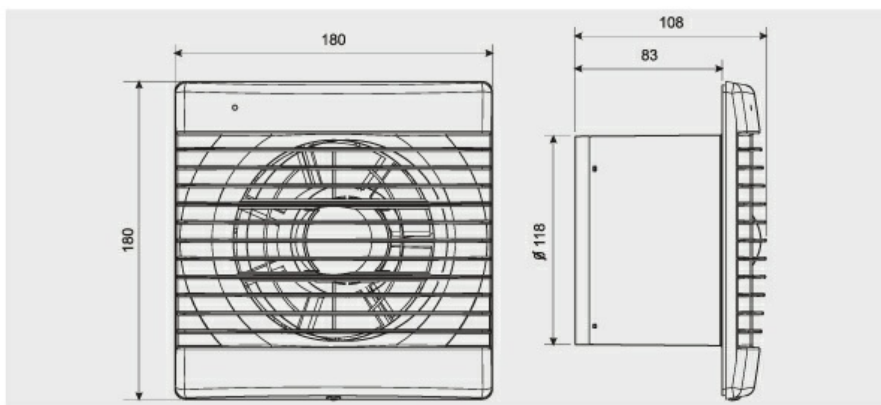

+ Curves

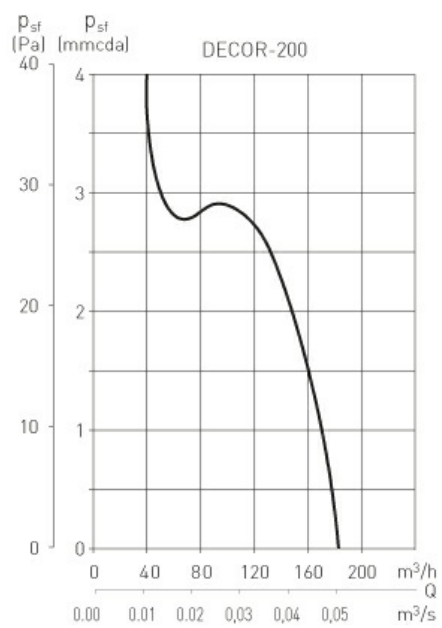

+ Models

DECOR-100 C 12V



IP57

PROTECTION



Model SELV (Safety Extra Low Voltage). Specially designed to operate within the shower or bath volume with total safety. They are rated 12V, Class III and IP57.

DECOR-100 12V must be wired to a safety isolating **transformer CT-12/14** which must be located out of the reach of the water spray or person using a bath or shower. The transformer is IP21, class II insulation and protected by fuse. Also available, **Transformer CT12/14 R**, supplied with adjustable run-on-timer between 1 to 30 minutes.

KIT DECOR-100 12V + CT

Kit integrated by an extractor DECOR-100 C 12V and a safety isolating transformer CT.

Versions: KIT DECOR-100 C 12V + CT-12/14
KIT DECOR-100 C 12V + CT-12/14 R

DECOR-100 CD DECOR-100 CDZ



Model provided with a PIR (passive infra-red) detector. The unit starts automatically when a movement is detected within a maximum distance of 4 meters from the fan. They are also fitted with an adjustable "run on" timer, from 1 to 30 minutes, to allow the fan continues operating after the initiation of the movement detection.

DECOR-100 CHZ VISUAL



Models provided with an electronic humidistat which can be adjusted to 60, 70, 80 or 90% HR using a key situated on the front grille. Four luminous indicators show the desired level of humidity. The extractor operates automatically when the humidity level in the room is higher than the set level. The extractor will stop automatically when the humidity drops below the selected level and after the selected period set on the adjustable timer (1 and 30 minutes).

+ Mounting Accessories



GSA-125
Flexible aluminium
ducting.



GRA-100
GRI-125
Aluminium exterior
grille.



PER-125W
Back draft shutter.

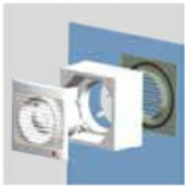

WINDOW KIT 200
Accessory to allow
DECOR-200 in a
window.