



Bathroom extract fans

SILENT-300 and SILENT-300 PLUS Series

SILENT-300



Range of axial extractors with airflow rates of approx. 280 m³/h, for connection to 150 mm diameter circular ducting. Motor mounted on silent-elastic-blocks (SILENT-300) which absorb the vibrations and allow offering very low noise level. All the fans are manufactured from injection moulded plastic, fitted with automatic shutter and single phase 230V-50Hz, class B low consumption motor equipped with thermal overload protection. All the fans are class II insulation, IP45 rated and suitable to operate with air temperature up to 40°C. The SILENT-300 CZ and CRZ can be supplied with an aesthetical silver front grille.

+ Attributes



Back draft shutter
To prevent air entry and limit heat leakage when the extractor is not operating. It opens due to the pressure of the air.



Silent-blocks
Motor mounted on "Silent-elastic-block" to prevent vibration and noise transmission. (SILENT-300)

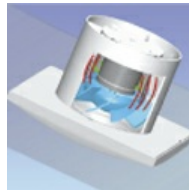

SILENT-300 Quiet operation
In usual extract fans the vibrations are transmitted to the surrounding areas while in SILENT extractor fans the vibrations are absorbed by the Silent Blocks.

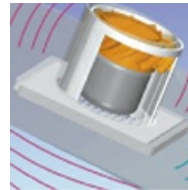

USUAL EXTRACTOR

+ Features

	CZ	CRZ	CHZ
PILOT LIGHT	•	•	•
BACKDRAFT SHUTTER	•	•	•
ADJUSTABLE RUN-ON-TIMER (1-30MIN)		•	•
ADJUSTABLE HUMIDISTAT			•
BALL BEARINGS	•	•	•

+ Technical characteristics

Model	Speed (r.p.m.)	Abs. power at free discharge (W)	Voltage (V) 50 Hz	Sound pressure level* (dB(A))	Airflow at free discharge (m ³ /h)	Insulation / IP	Ø duct (mm)	Weight (Kg)
SILENT-300	1700	29	230	32	280	Class II / IP45	150	1,25
SILENT-300 PLUS	2000	21	230	36	320	Class II / IP45	150	1,65

* Sound pressure level measured at 3 m at free air conditions.

+ Dimensions

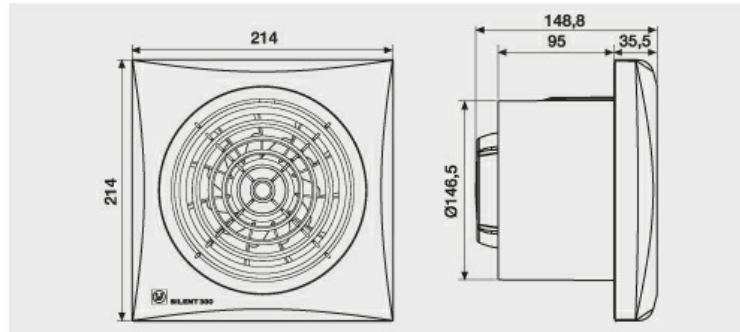

+ Curves

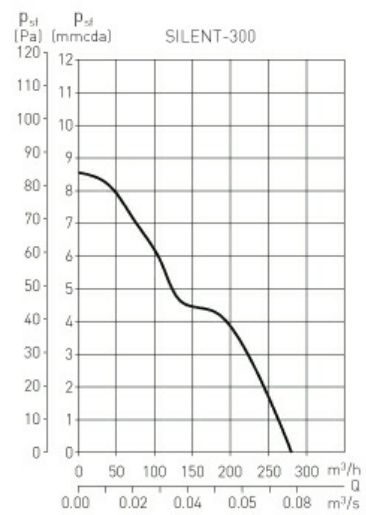

+ Models

SILENT-100 CZ 12V White color version

SILENT-100 CZ SILVER 12V Version with a silver color front grille



IP57

WATER
PROTECTED!



Model SELV (Safety Extra Low Voltage). Specially designed to operate within the shower or bath volume with total safety. They are rated 12V, Class III and IP57.

SILENT-100 12V must be wired to a safety isolating **Transformer CT-12/14** which must be located out of the reach of the water spray or person using a bath or shower. The transformer is IP21, class II insulation and protected by fuse. Also available, **Transformer CT12/14 R**, supplied with adjustable run-on-timer between 1 to 30 minutes.

KIT SILENT-100 CZ 12V + CT

Kit integrated by an extractor SILENT-100 CZ 12V and a safety isolating transformer CT-12/14.

SILENT-100 CDZ



Model provided with a PIR (passive infra-red) detector. The unit starts automatically when a movement is detected within a maximum distance of 4 meters from the fan. They are also fitted with an adjustable "run on" timer, from 1 to 30 minutes, to allow the fan continues operating after the initiation of the movement detection.

SILENT-100 CHZ VISUAL



Models provided with an electronic humidistat which can be adjusted to 60, 70, 80 or 90% HR using a key situated on the front grille. Four luminous indicators show the desired level of humidity. The extractor operates automatically when the humidity level in the room is higher than the set level. The extractor will stop automatically when the humidity drops below the selected level and after the selected period set on the adjustable timer [1 and 30 minutes].

+ Mounting Accessories



GSA-150
Flexible aluminium
ducting.



GRA-150
Aluminium exterior
grille.



REB
Back draft shutter.



CX-125/215
Worm drive ducting
clip.



PER-160W
Single phase
electronic speed
controllers.